

SILENSOR® by DAVEY



Model Number:
SLS, SLL



RESIDENTIAL



POOL PUMP

Revolutionary Water Cooled Pool Pumps

APPLICATION

Ideal for filtration, auto pool cleaning, backwashing, water features and spa jet operation. Also ideal with solar, gas and heat pump spa & pool heating.

SUPER-QUIET OPERATION AND HIGH EFFICIENCY

- **Super-Quiet** – Designed with a unique water-cooled motor which captures noise and vibrations, allowing super-quiet operation, rated between 54 and 56 dBa. Your neighbours won't even know it's there.
- **Long Lasting** – Silensor is designed for long service life in an outdoor, poolside environment and replaces highly corrodible metal components with high performance, long-life plastics for low maintenance and dependable service – year after year
- **Dependable** – Silensor incorporates unique dry run protection to minimise pump damage if no water is available to the pump. It also includes a unique mechanical seal protection for long service life and reduced maintenance
- **Convenient** – Patented water-cooled motor, Silensor does not require air ventilation, and gives installers more flexibility with pump positioning*
- **Double insulated to water circuit** – provided with an Equipotential Bonding Point for AS/NZ 3000 wiring standards
- **SLS models** – are an ideal replacement for many other pool pump models and are designed to retrofit with minimal hassle
- **SLL models** feature a large 4.5 litre leaf basket for long intervals between cleaning
- **Other Great Features**
 - Rust proof casing
 - Heavy duty motor impeller
 - 316 stainless steel pump shaft
 - Motor shell protection with new Armourspray VC (Epoxy)

Swimming Pool Pump

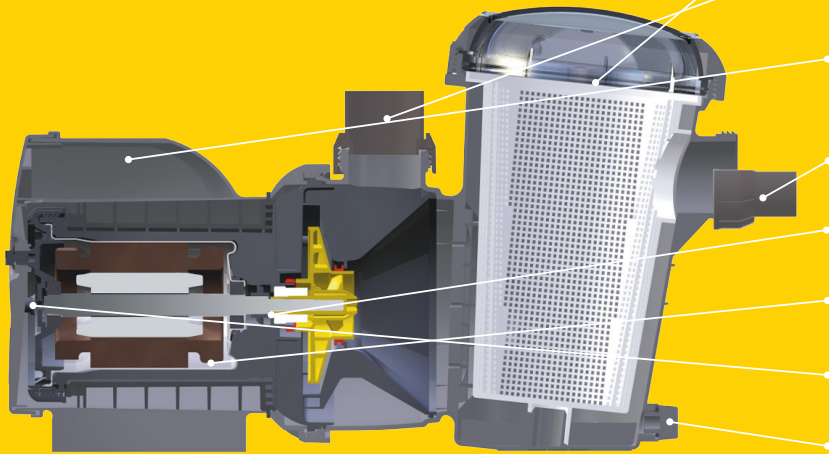

Large Leaf Basket (on SLL models) with easy to remove, clear lid

Dry running protection to protect the pump when there is no water inside the pump

Built with strong corrosion and UV-resistant polypropylene materials for long service life

Quality ABS quick coupling barrel unions for simple installation

High performance water cooled motor for quiet, efficient use all year round

Motor shell protection with Armourspray VC (Epoxy)

Double insulated to water circuit with Equipotential Bonding Point

Drain plug enables quick draining of the casing for easy removal and maintenance

ELECTRICAL DATA	Type	SLS100	SLS150	SLS200	SLS300	SLL200	SLL300	SLL400
	Voltage (V)	220/240						
	Supply Freq (Hz)	50						
	Motor Input Power (W/hp)	740/1.0	860/1.2	1090/1.5	1400/1.9	1130/1.5	1400/1.9	1760/2.4
	Motor Output Power (W/hp)	525/0.7	620/0.8	775/1.0	960/1.3	830/1.1	960/1.3	1200/1.6
	RPM	2850						
	Enclosure Class (IP)	56						
	Insulation Class	F						
	Approval No.	A/10EA						
	Lead Length	3m						

OPERATING LIMITS	Max water temperature	40°C
	Max ambient temperature	40°C
	Noise level (AS 5102.2)	54 to 56dBA

DIMENSIONS	Type	Mounting Holes Diameter	Inlet PVC	Outlet PVC	Net Weight (kg)
	SLS100	10 x 34	40	40	11.0
	SLS150		40	40	11.0
	SLS200		40	40	11.5
	SLS300		40	40	11.5
	SLL200		40 / 50	40 / 50	12.5
	SLL300		50	50	12.5
	SLL400		50	50	13.0

HYDRAULIC PERFORMANCE

